

FORM FIT Hood Protector Installation Instructions

HD 20Q17
Toyota Highlander (2017-2019)

Kit Contents



Metal mounting brackets (3)

Screws (9)



“L”brackets (6)

Pins (9)



Clip bodies (6)

Anti-abrasion pads (9)



Modified Clip Bodies (3)

Bumpons (2)



Push-type retainers (3)

Small Bumpons (5)



Hood protector blade (1)



Installation Procedure

NOTE: Vehicle surface temperature should be a minimum 15 degrees Celsius.

1. Be sure that the hood is clean and dry inside and out.
2. Install the (7) bumpons as shown.
Attention: Bumpons must be installed on the hood, not on the deflector.

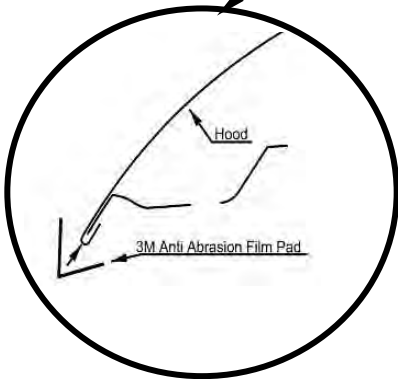
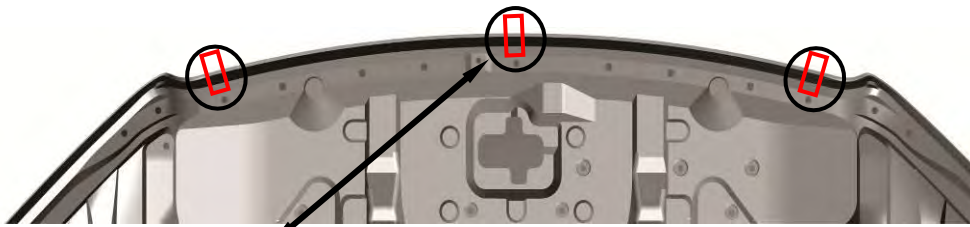
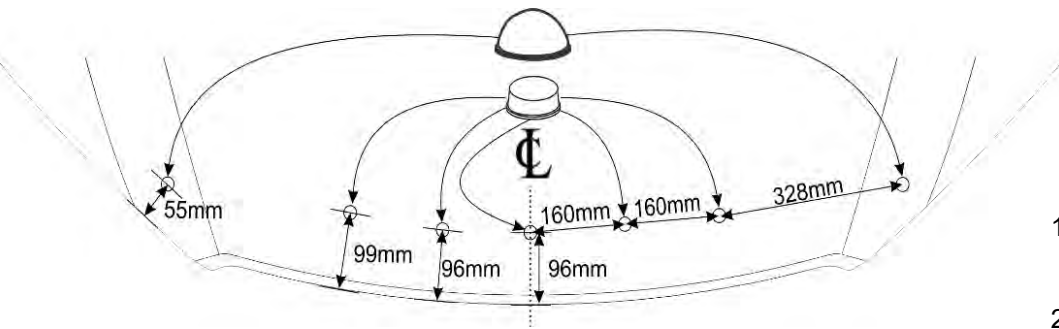

3. Open the hood of the vehicle. Peel and fold the anti-abrasion pads in half over the edge of the hood, in line with the (3) holes under the hood, as shown. *See illustration.*

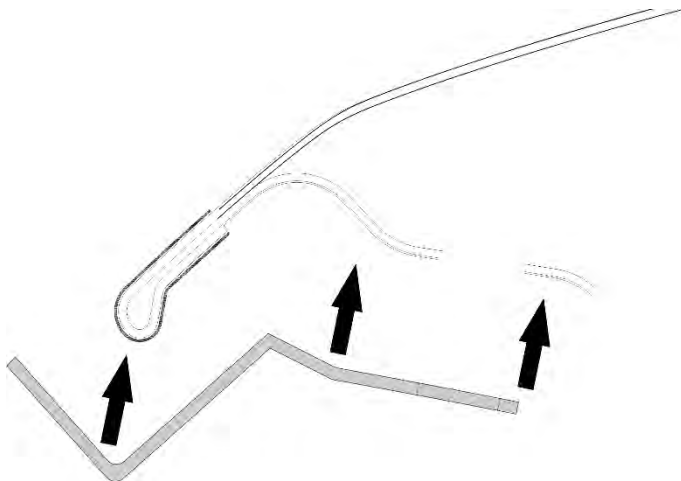

4. One at a time, place the metal bracket over the hood edge in their correct positions.

Align the hole in the bottom leg of the bracket with the round hole in the hood. *See Illustration.*

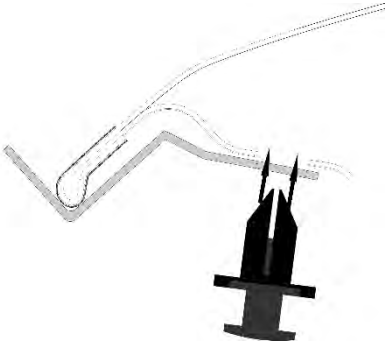

5. Insert a push-type retainer through the metal bracket and into the round hole in the hood. See *Illustration*.

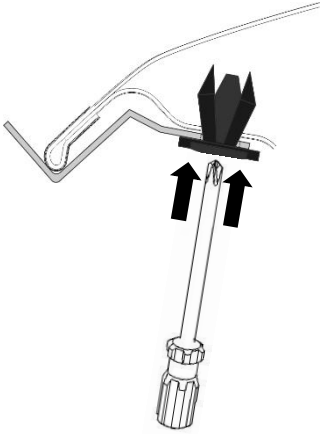

6. Once the push-type retainer is seated in the metal bracket, push the center pin into place. Use a Phillips head screwdriver and seat the center pin with a sharp push.

NOTE: Engaging the center pin of the “push-type retainer” is best accomplished by placing a #2 Philips drive screwdriver into the recess of the center pin and pushing the pin **followed by tightening 90 degrees to fully engage the retainer into the hood.**

The retainer can be removed by unthreading the center pin with a Philips screwdriver, however initial installation is best done using the “push” method described above.

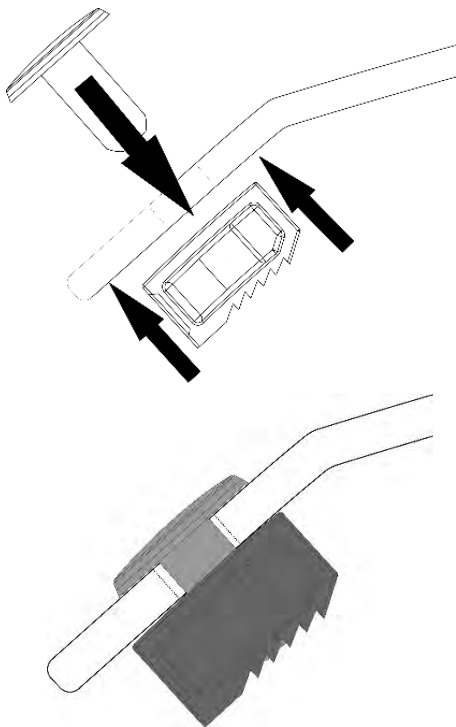

7. Place a pin through each of the three middle holes in the hood protector and into one of the modified clip bodies as shown.

Note the orientation of the clip body relative to the edge of the hood protector

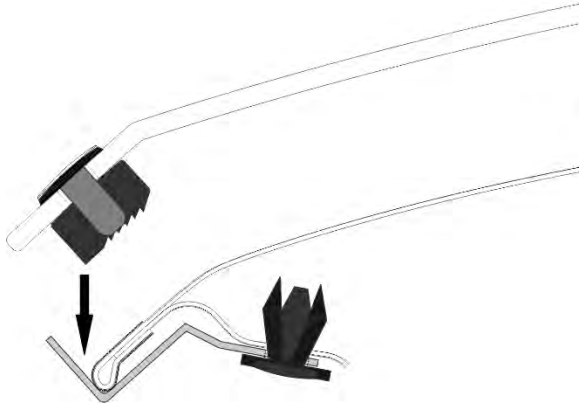

8. With all three pins and clips bodies in place, lower the hood protector onto the hood and align the holes in the 3 metal brackets with the holes in the clip bodies.

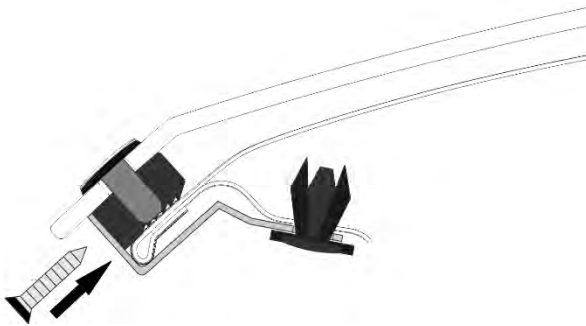

9. Insert a #6 x 5/8" screw through the metal bracket and into each clip body.



10. Ensure all metal brackets and clip bodies are properly aligned and tighten the screws into each of the three clip bodies.

****Note the orientation of the metal brackets. They should be perpendicular to the hood edge.* See illustration.***

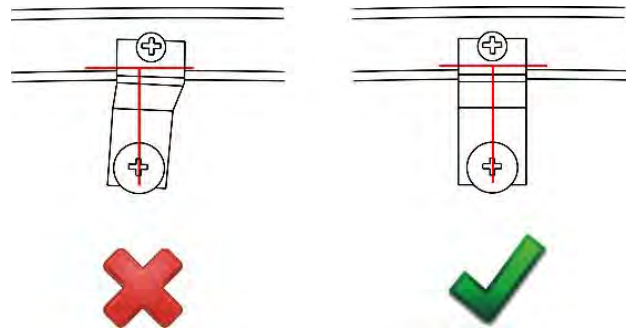

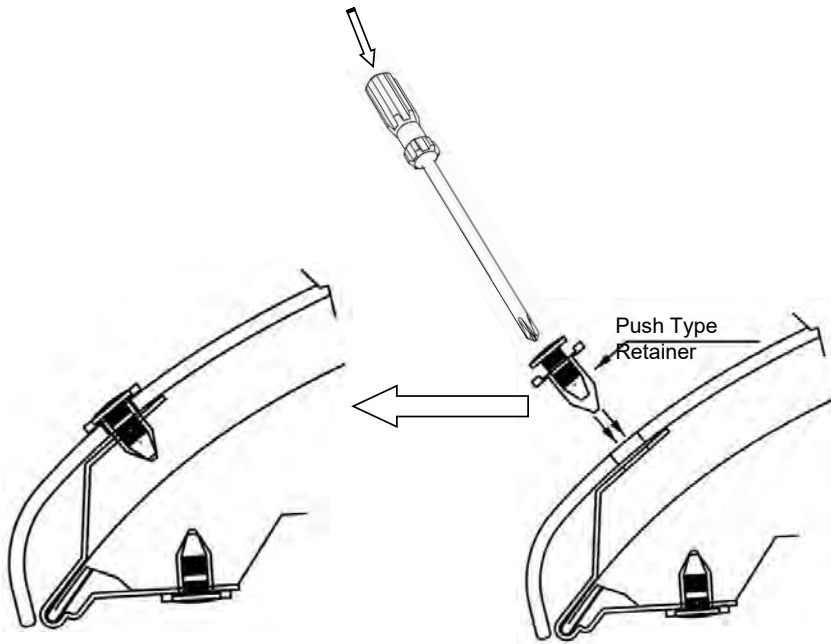

7. Align the 3 centre holes in the protector with the holes in the metal brackets.

- Insert a “push-type retainer” through the hole in a protector, and into the bracket below.
- Ensure the protector is seated against the metal bracket and push the centre pin of the retainer assembly to lock it into place.
- Repeat for the remaining push-type retainers.



8. Peel and fold the anti-abrasion pads in half over the edge of the hood in line with the three holes in the protector over each of the headlights. *See Illustration.* Repeat for remaining push-type retainers.

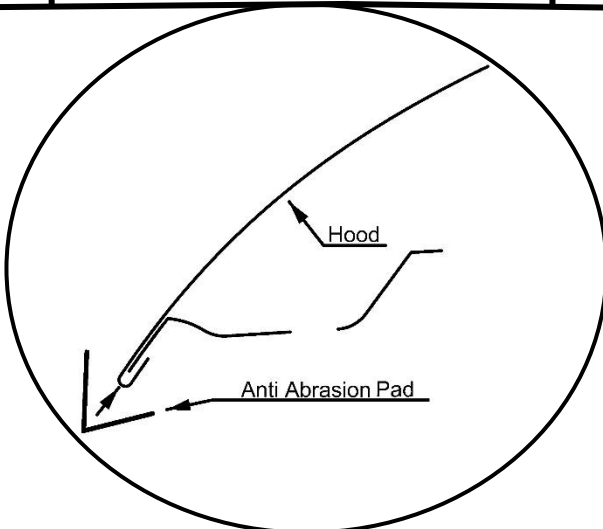

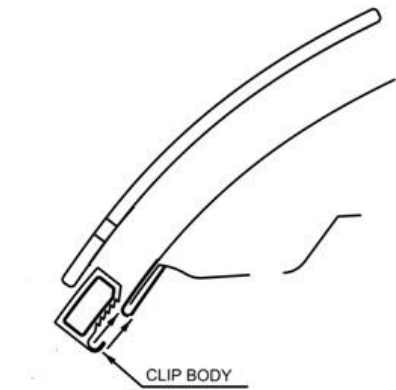

- Place a clip body over one of the anti-abrasion pads on the edge of the hood.

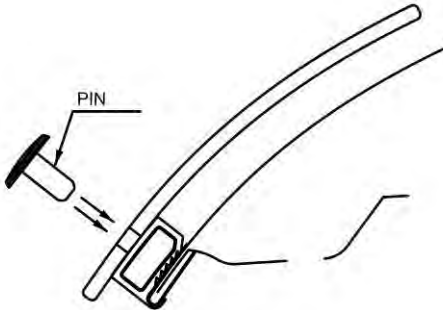

- Insert a pin through the protector and into the clip.

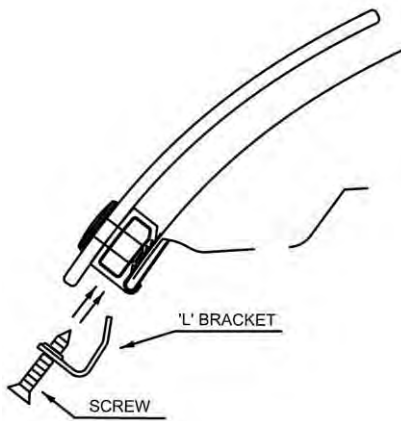

- Start a screw through an 'L'- bracket and into the clip a few turns.
- Repeat steps 9-11 to the remaining 5 clip assemblies.

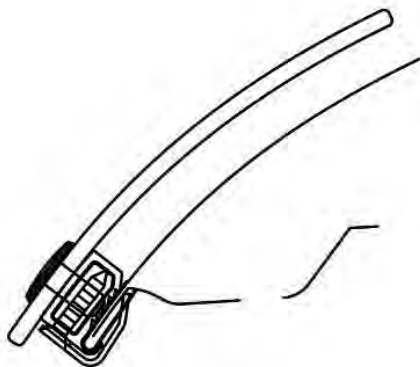

- Make sure all the components are well seated together and the protector is centered on the hood. Starting at the innermost clip locations, finish tightening the screws into the clips. *Do not overtighten.*

CARE INSTRUCTIONS

- Clean the protector with a mild soap and water solution or plastic cleaner only. Do not use chemicals or solvents.
- Periodically check to make sure the bumpers are in place and the protector is secure.
- Do not pull on the protector when opening or closing the hood.